

SPCE061A

16-bit Sound Controller with 32K x 16 Flash Memory

Preliminary

SEP. 09, 2003

Version 0.5

Table of Contents

| | <u>PAGE</u> |
|--|-------------|
| 1. GENERAL DESCRIPTION | 4 |
| 2. BLOCK DIAGRAM | 4 |
| 3. FEATURES | 4 |
| 4. APPLICATION FIELD | 4 |
| 5. SIGNAL DESCRIPTIONS | 5 |
| 5.1. ORDERING INFORMATION..... | 6 |
| 6. FUNCTIONAL DESCRIPTIONS | 7 |
| 6.1. CPU..... | 7 |
| 6.2. MEMORY..... | 7 |
| 6.3. PLL, CLOCK, POWER MODE..... | 7 |
| 6.4. POWER SAVINGS MODE..... | 7 |
| 6.5. LOW VOLTAGE DETECTION AND LOW VOLTAGE RESET..... | 8 |
| 6.6. INTERRUPT..... | 8 |
| 6.7. I/O..... | 8 |
| 6.8. TIMER / COUNTER..... | 9 |
| 6.9. SLEEP, WAKEUP AND WATCHDOG..... | 10 |
| 6.10. ADC (ANALOG TO DIGITAL CONVERTER) / DAC..... | 10 |
| 6.11. SERIAL INTERFACE I/O (SIO)..... | 11 |
| 6.12. UART..... | 11 |
| 6.13. AUDIO ALGORITHM..... | 11 |
| 6.14. IDE TOOLS FUNCTION..... | 11 |
| 6.15. BONDING OPTION SUMMARY..... | 12 |
| 6.16. SECURITY FUNCTION..... | 12 |
| 7. ELECTRICAL SPECIFICATIONS | 13 |
| 7.1. ABSOLUTE MAXIMUM RATINGS..... | 13 |
| 7.2. DC CHARACTERISTICS (VDD = 3.6V, VDD _{IO} = 3.6V (PORTA & B), T _A = 25°C)..... | 13 |
| 7.3. DC CHARACTERISTICS (VDD = 3.3V, VDD _{IO} = 5.5V (PORTA & B), T _A = 25°C)..... | 14 |
| 7.4. DC CHARACTERISTICS (VDD = 3.3V, VDD _{IO} = 3.3V (PORTA & B), T _A = 25°C)..... | 14 |
| 7.5. ADC CHARACTERISTICS (VDD = 3.3V, T _A = 25°C)..... | 15 |
| 7.6. V2VREF REGULATOR CHARACTERISTICS (VDD = 3.3V, T _A = 25°C)..... | 15 |
| 7.7. DAC CHARACTERISTICS (VDD = 3.3V, T _A = 25°C)..... | 15 |
| 7.8. PULL HIGH RESISTER AND VDD _{IO} | 16 |
| 7.9. I/O OUTPUT HIGH CURRENT I _{OH} AND V _{OH} | 16 |
| 7.10. PULL LOW RESISTER AND VDD _{IO} | 16 |
| 7.11. I/O OUTPUT LOW CURRENT I _{OL} AND V _{OL} | 16 |

| | |
|---|-----------|
| 8. APPLICATION CIRCUITS | 17 |
| 8.1. APPLICATION CIRCUIT - (1)..... | 17 |
| 8.2. APPLICATION CIRCUIT - (2)..... | 18 |
| 8.3. APPLICATION CIRCUIT - (3)..... | 19 |
| 8.4. APPLICATION CIRCUIT - (4)..... | 20 |
| 8.5. APPLICATION CIRCUIT - (5)..... | 21 |
| 8.6. APPLICATION CIRCUIT - (6)..... | 22 |
| 8.7. APPLICATION CIRCUIT - (7)..... | 23 |
| 9. PACKAGE/PAD LOCATIONS | 24 |
| 9.1. PAD ASSIGNMENT AND LOCATIONS | 24 |
| 9.2. PACKAGE INFORMATION | 25 |
| 10. DISCLAIMER | 29 |
| 11. REVISION HISTORY | 30 |

Sunplus Information
For Sunplus University Program
Use Only

16-BIT SOUND CONTROLLER WITH 32K X 16 FLASH MEMORY

1. GENERAL DESCRIPTION

The SPCE061A, a 16-bit architecture product, carries the newest 16-bit microprocessor, $\mu'nSP^{\text{TM}}$ (pronounced as *micro-n-SP*), developed by SUNPLUS Technology. This high processing speed assures the $\mu'nSP^{\text{TM}}$ is capable of handling complex digital signal processes easily and rapidly. Therefore, the SPCE061A is applicable to the areas of digital sound process and voice recognition. The operating voltage of 3.0V through 3.6V and speed of 0.32MHz through 49.152MHz yield the SPCE061A to be easily used in varieties of applications. The memory capacity includes 32K-word flash memory plus a 2K-word working SRAM. Other features include 32 programmable multi-functional I/Os, two 16-bit timers/counters, 32768Hz Real Time Clock, Low Voltage Reset/Detection, eight channels 10-bit ADC (one channel built-in MIC amplifier with auto gain controller), 10-bit DAC output and many others.

2. BLOCK DIAGRAM

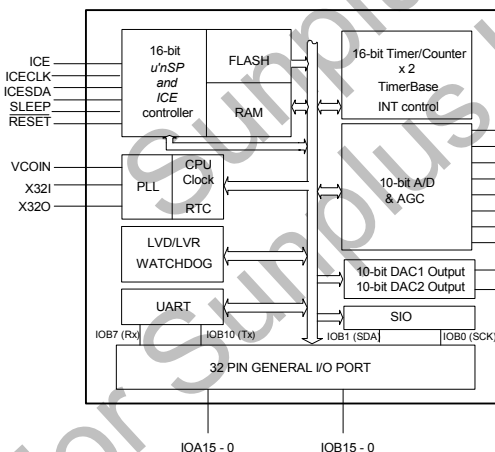

3. FEATURES

- 16-bit $\mu'nSP^{\text{TM}}$ microprocessor
- CPU clock: 0.32MHz - 49.152MHz
- Operating voltage: 3.0V - 3.6V
- Program Flash Operating voltage: 3.0V - 3.6V
- IO PortA & B operating voltage: 3.0V - 5.5V
- 32K-word flash memory
- 2K-word working SRAM
- Software-based audio processing
- Crystal Resonator
- Standby mode (Clock Stop mode) for power savings, Max. 2.0 μ A @ VDD = 3.6V
- Two 16-bit timers/counters
- Two 10-bit DAC outputs
- 32 general I/Os (bit programmable)
- 14 INT sources with two priority levels
- Key wakeup function (IOA0 - 7)
- Approx. 210 sec speech @ 2.4Kbit/per sec with SACM_S240
- PLL feature for system clock
- 32768Hz Real Time Clock (RTC)
- Eight channels 10-bit AD converter
- ADC external top reference voltage
- 2.0V voltage regulator output, 5mA of driving capability
- Serial interface I/O (SIO)
- Built-in microphone amplifier and AGC function
- UART receiver and transmitter (full duplex)
- Low voltage reset and low voltage detection
- Watchdog enable (bonding option)
- ICE function for development and down load into flash memory
- Security function to protect code to be read and written.

4. APPLICATION FIELD

- Voice recognition products
- Intelligent interactive talking toys
- Advanced educational toys
- Kids learning products
- Kids storybook
- General speech synthesizer
- Long duration audio products
- Recording / playback products

5. SIGNAL DESCRIPTIONS

| Mnemonic | PIN No. | Type | Description |
|-------------|------------|------|--|
| IOA [15:8] | 46 - 39 | I/O | IOA [15:8]: bi-directional I/O ports |
| IOA [7:0] | 34 - 27 | I/O | IOA [7:0] can be software programmed to wakeup I/O pins IOA [6:0] can be optioned as ADC Line-in input |
| IOB [15:11] | 50 - 54 | I/O | IOB [15:11]: bi-directional I/O ports |
| IOB 10 | 57 | I/O | IOB10 can also be selected as UART Transmitter (Tx). |
| IOB 9 | 58 | I/O | IOB9 can also be Multi-duty cycle output of TimerB (BPWMO). |
| IOB 8 | 59 | I/O | IOB8 can also be Multi-duty cycle output of TimerA (APWMO). |
| IOB 7 | 60 | I/O | IOB7 can also be selected as UART receiver (Rx). |
| IOB 6 | 61 | I/O | IOB6 is a bi-directional I/O ports. |
| IOB 5 | 62 | I/O | IOB5 can also be selected as feedback signal with EXT2. |
| IOB 4 | 63 | I/O | IOB4 can also be selected as feedback signal with EXT1. |
| IOB 3 | 64 | I/O | IOB3 can also be selected as an external interrupt input pin (EXT2)(Negative-edge Triggered). |
| IOB 2 | 65 | I/O | IOB2 can also be selected as an external interrupt input pin (EXT1)(Negative-edge Triggered). |
| IOB 1 | 66 | I/O | IOB1 can also be selected as a serial interface data. (SDA) |
| IOB 0 | 67 | I/O | IOB0 can also be selected as a serial interface clock (SCK) |
| DAC1 | 12 | O | Audio DAC1 output |
| DAC2 | 13 | O | Audio DAC2 output |
| X32I | 2 | I | Oscillator Crystal input |
| X32O | 1 | O | Oscillator Crystal output |
| VCOIN | 70 | I | RC filter connection for PLL |
| AGC | 16 | I | AGC control pin |
| MICN | 19 | I | Microphone differential input (negative) |
| MICP | 21 | I | Microphone differential input (positive) |
| V2VREF | 14 | O | 2.0V output voltage, 5.0mA of driving capability (can be used as external ADC Line_IN top reference voltage) |
| MICOUT | 18 | O | Microphone 1 st amplifier output |
| OPI | 17 | I | Microphone 2 nd amplifier input |
| VEXTREF | 23 | I | ADC Line_IN top external reference voltage input pin |
| VMIC | 25 | O | Microphone power supply |
| VADREF | 22 | O | AD reference voltage (generated by internal AD converter). |
| VDD | 5, 69 | I | Positive supply for logic |
| VSS | 10, 26, 71 | I | Ground reference for logic and I/O pins |
| VDDIO | 37, 38, 56 | I | Positive supply for I/O pins |
| VSSIO | 35, 36, 48 | I | Ground reference for I/O pins |
| AVDD | 24 | I | Positive supply for analog circuit including ADC, DAC and 2.0V regulator |
| AVSS | 15 | I | Ground reference for analog circuit including ADC, DAC and 2.0V regulator |
| RESET | 68 | I | An active low reset to the chip |
| SLEEP | 49 | O | Sleep mode (active high) |
| ICE | 7 | I | ICE enable (active high) |
| ICECLK | 8 | I | ICE serial interface clock |
| ICESDA | 9 | I/O | ICE serial interface data |
| TEST | 3 | I | Connected to high for test mode, normally connected to GND (test mode disabled) or unconnected. |
| ROMT | 47 | I | Flash memory test, normally unconnected. |

| Mnemonic | PIN No. | Type | Description |
|-------------|---------|------|--|
| N/C | 55 | I | Not used. |
| N/C | 4 | I | Do NOT bonding and connect this pin. If user bonding this pin, IC will not work. |
| WDGOPT* | 6 | I | Connected to high for watchdog disabled, unconnected for watchdog enabled. |
| PFUSE, PVIN | 20, 11 | I | Security enable using fuse. |

Note*: WDGOPT is the watchdog option pin, selected by bonding option. Remain WDGOPT float (unconnected to VDD) to enable the watchdog. In contrast, connecting WDGOPT to VDD will disable watchdog. The reason of placing WDGOPT adjacent to VDD is to facilitate connection between VDD and WDGOPT when disabling watchdog is necessary.

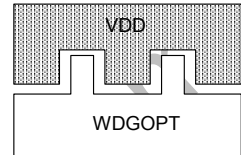

5.1. Ordering Information

| Product Number | Package Type |
|-----------------------|------------------------|
| SPCE061A-NnnV-C | Chip form |
| SPCE061A-NnnV-PL04n-W | Package form - LQFP 80 |
| SPCE061A-NnnV-PP07n-W | Package form - PLCC 84 |

Note1: Code number is assigned for customer.

Note2: Code number (N = A - Z or 0 - 9, nn = 00 - 99); version (V = A - Z).

Note3: PL04n-W, PL04 is assign for LQFP80, n is assign for customer, W is watch dog bonding option (W=0 enable, W=1 disable)

6. FUNCTIONAL DESCRIPTIONS

6.1. CPU

The SPCE061A is equipped with a 16-bit $\mu'nSP^{\text{TM}}$, the newest 16-bit microprocessor by SUNPLUS and pronounced as *micro-n-SP*. Eight registers are involved in $\mu'nSP^{\text{TM}}$: R1 - R4 (General-purpose registers), PC (Program Counter), SP (Stack Pointer), Base Pointer (BP) and SR (Segment Register). The interrupts include three FIQs (Fast Interrupt Request) and eight IRQs (Interrupt Request), plus one software-interrupt, BREAK.

Moreover, a high performance hardware multiplier with the capability of FIR filter is also built in to reduce the software multiplication loading.

6.2. Memory

6.2.1. SRAM

The amount of SRAM is 2K-word (including Stack), ranged from \$0000 through \$07FF with access speed of two CPU clock cycles.

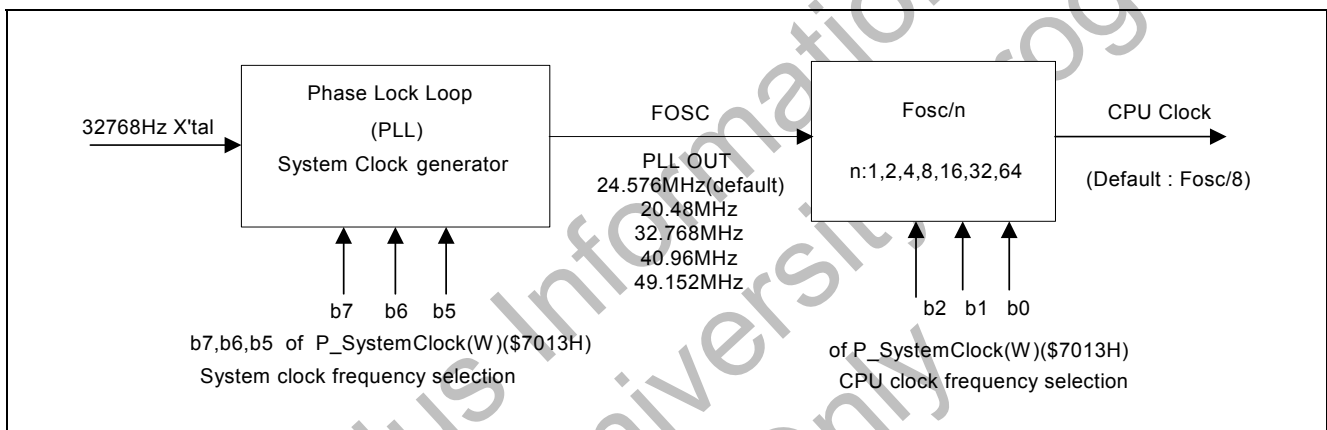

6.2.2. Flash memory

Flash memory (\$008000 ~ \$00FFFF) is a high-speed memory with access speed of two CPU clock cycles. FLASH erase and program functions must be used in IDE tools.

wake CPU up whenever RTC occurs. Since the RTC is generated each 0.5 seconds, time can be traced by the numbers of RTC occurrence. In addition, SPCE061A supports 32768Hz oscillator in strong mode and auto_weak mode. In strong mode, 32768Hz OSC always runs at the highest power consumption. In auto_weak mode, however, it runs in strong mode for the first 7.5 seconds and changes back to auto_weak mode automatically to save powers.

6.3. PLL, Clock, Power Mode

6.3.1. PLL (Phase Lock Loop)

The purpose of PLL is to provide a base frequency (32768Hz) and to pump the frequency from 20.48MHz to 49.152MHz for system clock (Fosc). The default PLL frequency is 24.576MHz.

6.3.1.1. System clock

Basically, the system clock is provided by PLL and programmed by the Port_SystemClock (W) to determine the frequency of clock for system. The default system clock Fosc = 24.576MHz and CPU clock is Fosc/8 if not specified. The initial CPU clock is Fosc/8 after system wakes up and to be adjusted to desired CPU clock by programming the Port_SystemClock (W). This avoids Flash ROM reading failure when system wakes up.

6.3.1.2. 32768Hz RTC

The Real Time Clock (RTC) is normally used in watch, clock or other time related products. A 2Hz-RTC (1/2 second) function is loaded in SPCE061A. The RTC counts the timing as well as to

6.4. Power Savings Mode

The SPCE061A also offers a power savings mode (standby mode) for low power application needs. To enter standby mode, the desired key wakeup port (IOA[7:0]) must be configured to input first. And read the Port_IOA_Latch(R) to latch the IOA state before entering the standby mode. Also remember to enable the corresponding interrupt source(s) for wakeup. After that, stop the CPU clock by writing the STOP CLOCK Register (b0~b2 of Port_SystemClock (W)) to enter standby mode. In such mode, SRAM and I/Os remain in the previous states till CPU being awoken. The wakeup sources in SPCE061A include Port IOA7 - 0 and IRQ1 - IRQ6. After SPCE061A is awoken, the CPU will continue to execute the program. Programmer can also enable or disable the 32768Hz OSC when CPU is in standby mode.

6.5. Low Voltage Detection and Low Voltage Reset

6.5.1. Low voltage detection (LVD)

There are two LVD levels to be selected: 2.9V, and 3.3V. These levels can be programmed via Port_LVD_Ctrl (W). As an example, suppose LVD is given to 2.9V. When the voltage drops below 2.9V, the b15 of Port_LVD_Ctrl is read as HIGH. In such state, program can be designed to react to this condition.

6.5.2. Low voltage reset

In addition to the LVD, the SPCE061A has another important function, Low Voltage Reset (LVR). With the LVR function, a reset signal is generated to reset system when the operating voltage drops below 2.3V for 4 consecutive clock cycles. Without LVR, the CPU becomes unstable and malfunction when the operating voltage drops below 2.3V. The LVR will reset all functions to the initial operational (stable) states when the voltage drops below 2.3V. A LVR timing diagram is given as follows:

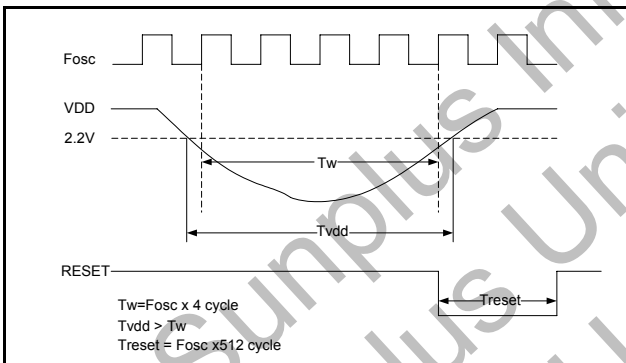

6.6. Interrupt

The SPCE061A has 14 interrupt sources, grouped into two types, FIQ (Fast Interrupt Request) and IRQ (Interrupt request). The priority of FIQ is higher than IRQ. FIQ is the high-priority interrupt while IRQ is the low-priority one. An IRQ can be interrupted by a FIQ, but not by another IRQ. A FIQ cannot be interrupted by any other interrupt sources.

| Interrupt Source | Interrupt Name | Priority |
|-----------------------|-------------------|-----------|
| Fosc/1024 | FIQ_PWM/IRQ0_PWM | High(FIQ) |
| Timer A | FIQ_TMA/ IRQ1_TMA | High(FIQ) |
| Timer B | FIQ_TMB/ IRQ2_TMB | High(FIQ) |
| EXT2 | IRQ3_EXT2 | Low |
| EXT1 | IRQ3_EXT1 | Low |
| Key change wakeup | IRQ3_KEY | Low |
| 4096Hz | IRQ4_4KHz | Low |
| 2048Hz | IRQ4_2KHz | Low |
| 1024Hz | IRQ4_1KHz | Low |
| 4Hz | IRQ5_4Hz | Low |
| 2Hz | IRQ5_2Hz | Low |
| Time-base 1 | IRQ6_TMB1 | Low |
| Time-base 2 | IRQ6_TMB2 | Low |
| UART (TxRDY or RxRDY) | UART IRQ | Low |

6.7. I/O

Two I/O ports are built in SPCE061A, PortA and PortB. The PortA is an ordinary I/O with programmable wakeup capability. In addition to the regular IO function, the PortB can also perform some special functions in certain pins. Suppose operating voltage is running at 3.6V (VDD) and VDDIO (power for I/O) operates from 3.6V (VDD) to 5.5V. In such condition, the I/O pad is capable of operating from 0V through VDDIO. However IOB13 and IOB14 are recommended to operate $\leq 3.6V$ during standby mode, otherwise these two IOs will have current leakage. The following diagram is an I/O schematic.

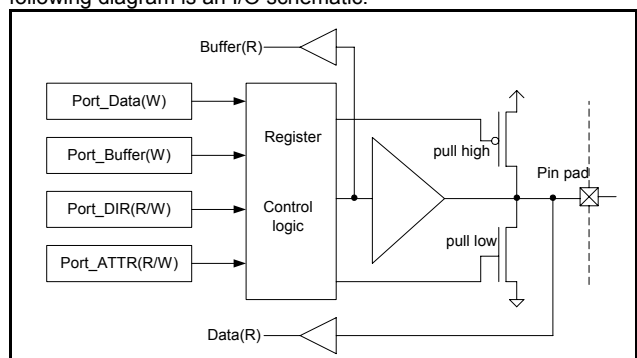

Although data can be written into the same register through Port_Data and Port_Buffer, they can be read from different places, Buffer (R) and Data (R). The IOA [7:0] is the key wakeup port. To activate key wakeup function, latch data on PORT_IOA_Latch

and enable the key wakeup function. Wakeup is triggered when the PortA state is different from at the time latched. In addition to an ordinary I/O port, PortB carries some special functions. A summary of PortB special functions is listed as follows:

Special function in PortB

| PortB | Special Function | Function Description | Note |
|-------|------------------|---|--------------------------------|
| IOB0 | SCK | Serial interface clock | Refer to see SIO section |
| IOB1 | SDA | Serial interface data | Refer to see SIO section |
| IOB2 | EXT1 | External interrupt source 1(Negative-edge Triggered) | IOB2 set as input mode |
| | Feedback Output1 | Works with IOB4 by adding a RC circuit between them to get an OSC to EXT1 interrupt | IOB2 set as inverted output |
| IOB3 | EXT2 | External interrupt source 2(Negative-edge Triggered) | IOB3 set as input mode |
| | Feedback Output2 | Works with IOB5 by adding a RC circuit between them to get an OSC to EXT2 interrupt | IOB3 set as inverted output |
| IOB4 | Feedback Input1 | | |
| IOB5 | Feedback Input2 | | |
| IOB7 | Rx | UART Receiver | Refer to see UART section |
| IOB8 | APWMO | TimerA PWM output | Refer to Timer/Counter section |
| IOB9 | BPWMO | TimerB PWM output | Refer to Timer/Counter section |
| IOB10 | Tx | UART Transmitter | Refer to UART section |

Default state: Pull Low

PWM: Pulse Width Modulation

Refer to the above table, the configuration of IOB2, IOB3, IOB4, and IOB5 involves feedback function in which an OSC frequency can be obtained from EXT1 (EXT2) by simply adding a RC circuit between IOB2 (IOB3) and IOB4 (IOB5).

6.8. Timer / Counter

The SPCE061A provides two 16-bit timers/counters, TimerA and TimerB. The TimerA is called a universal counter. TimerB is a general-purpose counter. The clock source of TimerA comes from the combination of clock source A and clock source B. In TimerB, the clock source is given from source C. When timer overflows, an INT signal is sent to CPU to generate a time-out signal.

| Clock of Source A | Clock of Source B | Clock of Source C |
|-------------------|-------------------|-------------------|
| Fosc/2 | 2048Hz | Fosc/2 |
| Fosc/256 | 1024Hz | Fosc/256 |
| 32768Hz | 256Hz | 32768Hz |
| 8192Hz | TMB1 | 8192Hz |
| 4096Hz | 4Hz | 4096Hz |
| 1 | 2Hz | 1 |
| 0 | 1 | 0 |
| EXT1 | EXT2 | EXT1 |

Initially, write a value of N into a timer and select a desired clock source, timer will start counting from N, N+1, N+2, ... through FFFF. An INT (TimerA/TimerB) signal is generated at the next clock after reaching "FFFF" and the INT signal is transmitted to INT controller for further processing. At the same time, N will be reloaded into timer and start all over again. The clock source A is a high frequency source and clock source B is a low frequency source. The combination of clock source A and B provides a variety of speeds to TimerA. A "1" represents pass signal and not gating. In contrast, "0" indicates deactivating timer. The EXT1 and EXT2 are the external clock sources. Moreover, counter can generate time-out signal for input clock source to a four bits (16 levels) PWM pulse width counter. A variety of clock duration can be generated and exported from IOB8 (APWMO) and IOB9 (BPWMO).

The following example is a 3/16-duration cycle. The APWMO waveform is made by selecting a pulse width through Port_TimerA_Ctrl (W) [9:6]. As a result, each 16 cycles will generate a pulse width defined in control port. These PWM signals can be applied for controlling the speed of motor or other devices.

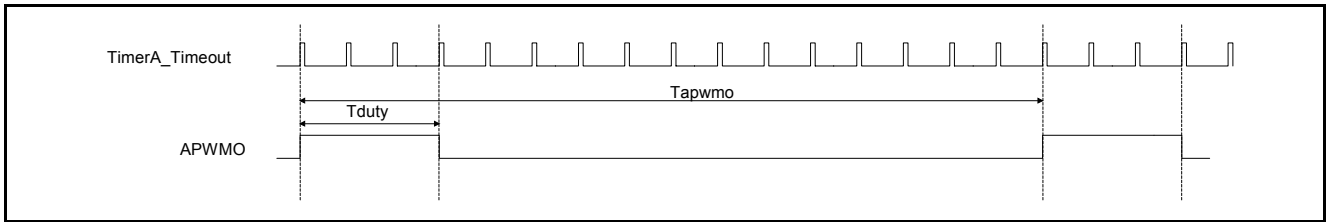

Generally speaking, the clock source A and C are fast clock sources and source B comes from RTC system (32768Hz). Therefore, clock source B can be utilized as a precise counter for time counting, e.g., the 2Hz clock can be used for real time counting.

6.8.1. Timebase

Timebase, generated by 32768Hz, is a combination of frequency selections. The outputs of timebase block are named to TMB1 and TMB2. TMB1 is frequency for TimerA (Clock source B). The TMB1 and TMB2 are the sources for Interrupt (IRQ6). Furthermore, timebases generates additional 2Hz to 4096Hz interrupt sources (IRQ4 and IRQ5) for Real-Time-Clock (RTC).

| TMB2 | TMB1 |
|----------------|--------------|
| 128Hz | 8Hz |
| 256Hz | 16Hz |
| 512Hz | 32Hz |
| 1024Hz | 64Hz |
| Default: 128Hz | Default: 8Hz |

6.9. Sleep, Wakeup and Watchdog

6.9.1. Wakeup and sleep

- 1) Sleep: After power-on reset, IC starts running until a sleep command occurs. When a sleep command is accepted, IC will turn the system clock (PLL) off. After all, it enters sleep mode.
- 2) Wakeup: CPU waking up from sleep mode requires a wakeup signal to turn the system clock (PLL) on. The IRQ signal makes CPU to complete the wakeup process and initialization. The key wakeup and interrupt sources (IRQ1 - IRQ6) can be used for wakeup sources.

6.9.2. Watchdog

The purpose of watchdog is to monitor if the system operates normally. Within a certain period, watchdog must be cleared. If watchdog is not cleared, CPU assumes the program has been running in an abnormal condition. As a result, the CPU will reset the system to the initial state and start running the program all over again. The watchdog function can be removed by bonding option. In SPCE061A, the clear period is 0.75 seconds. If watchdog is cleared within each 0.75 seconds, the system will not be reset. To clear watchdog, simply write "0bxxxx xxxx xxxx xx01" to Port_Watchdog_Clear(W). The content written to Port_Watchdog_Clear (W) for watchdog clearance must be exactly the same as the one illustrated above (0bxxxx xxxx xxxx xx01). Other values given to the Port_Watchdog_Clear (W) for watchdog clearance may end up with system reset. The watchdog function remains enabled during standby mode if the 32768Hz is turned on.

6.10. ADC (Analog to Digital Converter) / DAC

The SPCE061A has eight channels 10-bit ADC (Analog to Digital Converter). The function of an ADC is to convert analog signal to digital signal, e.g. a voltage level into a digital word. The eight channels of ADC can be seven channels of line-in from IOA [6:0] or one channel microphone (MIC) input through amplifier and AGC controller. The MIC amplifier circuit is capable of reducing common mode noise by transmitting signals through differential MIC Inputs (MICN, MICP). Moreover, an external resistor can be applied to adjust microphone gain and time of AGC operating. The AD needs to select source of line-in before conversion. The ADC is able to choose the external or internal (=AVDD) top reference voltage. If constant voltage source is unavailable, SPCE061A offers a constant voltage 2.0V with 5.0mA driving ability with a capacitor connected.

The SPCE061A has two 10-bit D/A with 2.0mA or 3.0mA driving current for audio outputs, DAC1 and DAC2.

6.11. Serial Interface I/O (SIO)

Serial interface I/O offers a one-bit serial interface for receiving data via two I/O pins, IOB0 (SCK) and IOB1 (SDA). This serial interface is capable of transmitting or

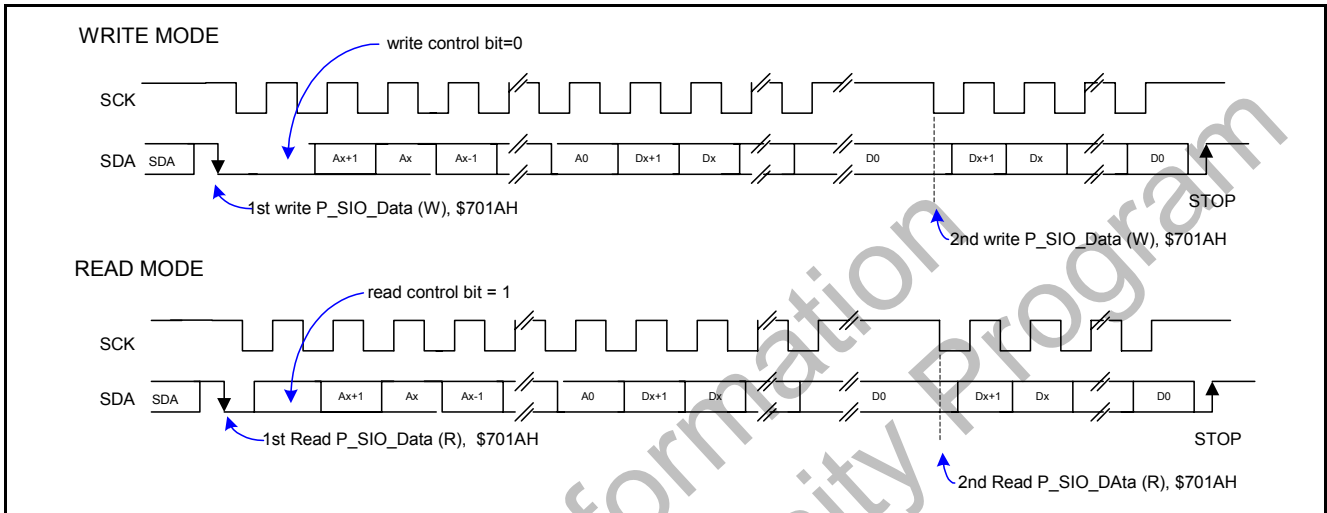

6.12. UART

UART block provides a full-duplex standard interface that facilitates the communication with other devices. With this interface, SPCE can transmit and receive simultaneously. The maximum baud-rate can be up to 115200bps. This function can be accomplished by using PortB and Interrupt (UART IRQ). The

Rx and Tx of UART are shared with IOB7 and IOB10. When SPCE061A receives and/or transmits a frame of data, the b7 (RxRDY) and/or b6 (TxRDY) in Port_UART_Command2(R) will be set to "1" and the UART IRQ is activated at the same time.

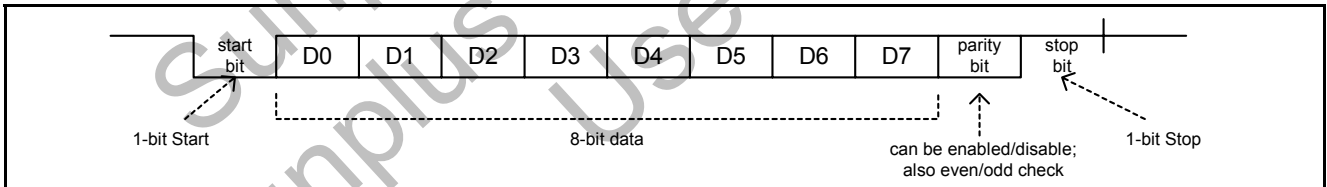

6.13. Audio Algorithm

The following speech types can be used in SPCE061A: PCM, LOG PCM, SACM_S200, SACM_S240, SACM_S480, SACM_S530, SACM_S720, SACM_A1600, SACM_A2000, SACM_A3200 and SACM_A2000_DVR (Digital Voice Recorder). For melody synthesis, the SPCE061A supports SACM_MS01 (FM) and SACM_MS02 (wave-table) synthesizers.

6.14. IDE Tools Function

The functions of IDE include the follows:

- 1). C compiler, Assembly, and Linker.
- 2). Download program into FLASH (refer to 7.7.application circuit-(7)).
- 3). Single step trace
- 4). Break point (break point for debugging)
- 5). Run (execute)

6.15. Bonding Option Summary

The SPCE061A has the following bonding options:

6.15.1. Watchdog function

WDGOPT is the optional pin for watchdog by bonding option. The shape looks as the figure given below. When watchdog is selected, WDGOPT is floating. If watchdog is not selected, WDGOPT is connected to VDD. The reason for WDGOPT adjacent to VDD is that when watchdog is not selected, it is easy to make the connection between VDD and WDGOPT.

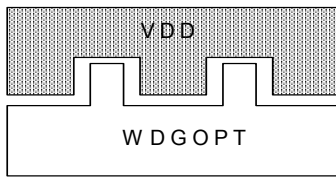

6.16. Security Function

Security function is able to protect code to be read or written. When program is downloaded into flash memory, program can be read/written protection from IDE tools for security purpose. Burn fuse to disable IDE function, where PFUSE supplies 5.0V and PVIN connects to ground (0V) about one second. After all, the flash memory can no longer be read or written.

For Sunplus Information University Program Use Only

7. ELECTRICAL SPECIFICATIONS

7.1. Absolute Maximum Ratings

| Characteristics | Symbol | Ratings |
|----------------------------|------------|-----------------------|
| DC Supply Voltage | V_+ | < 4.0V |
| PortA/B Pad Supply Voltage | VDD_{IO} | < 7.0V |
| Input Voltage Range | V_{IN} | -0.5V to V_+ + 0.5V |
| Operating Temperature | T_A | 0°C to +60°C |
| Storage Temperature | T_{STO} | -50°C to +150°C |

Note: Stresses beyond those given in the Absolute Maximum Rating table may cause operational errors or damage to the device. For normal operational conditions see DC Electrical Characteristics.

7.2. DC Characteristics (VDD = 3.6V, VDD_{IO} = 3.6V (PortA & B), T_A = 25°C)

| Characteristics | Symbol | Limit | | | Unit | Test Condition |
|--|-----------|-------|------|----------------------|------------|---|
| | | Min. | Typ. | Max. | | |
| Operating Voltage | VDD | 3.0 | 3.3 | 3.6 | V | |
| Operating Current | I_{OP} | - | - | 33 | mA | $F_{OSC} = 49.152MHz$, AD, DAC disable, no load |
| Standby Current | I_{STB} | - | - | 2.0 | μA | Disable 32KHz crystal |
| | | | | 5.0 | | Enable 32KHz, Disable PLL (F_{osc}) |
| Input High Level | V_{IH} | - | - | 0.7VDD _{IO} | V | |
| Input Low Level | V_{IL} | - | - | 0.3VDD _{IO} | V | |
| Output DAC current (AUD1, AUD2) | I_{AUD} | - | - | -2.0 | mA | 2.0mA mode |
| | | | | -3.0 | | 3.0mA mode |
| Output High Current | I_{OH} | - | - | -3.2 | mA | $V_{OH} = 2.9V$ |
| Output Low Current | I_{OL} | - | - | 7.0 | mA | $V_{OL} = 0.7V$ |
| Input Pull-Low Resister (PA15 :0, PB15 :0) | R_{PL} | - | - | 165 | K Ω | $VDD_{IO} = 3.6V$ $V_{IN} = VDD$ |
| Input Pull-High Resister (PA15 :0, PB15 :0) | R_{PH} | - | - | 210 | K Ω | $VDD_{IO} = 3.6V$ $V_{IN} = VSS$ |

7.3. DC Characteristics (VDD = 3.3V, VDD_{IO} = 5.5V (PortA & B), T_A = 25°C)

| Characteristics | Symbol | Limit | | | Unit | Test Condition | |
|--|------------------|-------|----------------------|------|------|--|------------------------|
| | | Min. | Typ. | Max. | | | |
| Operating Voltage | VDD | 3.0 | 3.3 | 3.6 | V | | |
| Operating Current | I _{OP} | - | 26 | - | mA | F _{OSC} = 49.152MHz, AD, DAC disable, no loading | |
| Standby Current | I _{STB} | - | - | 2.0 | μA | Disable 32KHz crystal When IOB13, IOB14 ≤ 3.6V | |
| | | | | 5.0 | | Enable 32KHz, Disable PLL (Fosc) When IOB13, IOB14 ≤ 3.6V | |
| Input High Level | V _{IH} | - | 0.7VDD _{IO} | - | V | | |
| Input Low Level | V _{IL} | - | 0.3VDD _{IO} | - | V | | |
| Output DAC current (AUD1, AUD2) | I _{AUD} | - | -2.0 | - | mA | 2.0mA mode | For one channel DAC |
| | | | -3.0 | | | 3.0mA mode | |
| Output High Current | I _{OH} | - | -5.0 | - | mA | V _{OH} = 4.0V | |
| Output Low Current | I _{OL} | - | 12 | - | mA | V _{OL} = 1.0V | |
| Input Pull-Low Resistor (PA15 :0, PB15 :0) | R _{PL} | - | 110 | - | KΩ | VDD _{IO} = 5.5V V _{IN} = VDD | |
| Input Pull-High Resistor (PA15 :0, PB15 :0) | R _{PH} | - | 150 | - | KΩ | VDD _{IO} = 5.5V V _{IN} = VSS | |

7.4. DC Characteristics (VDD = 3.3V, VDD_{IO} = 3.3V (PortA & B), T_A = 25°C)

| Characteristics | Symbol | Limit | | | Unit | Test Condition | |
|--|------------------|-------|----------------------|------|------|--|------------------------|
| | | Min. | Typ. | Max. | | | |
| Operating Voltage | VDD | 3.0 | 3.3 | 3.6 | V | | |
| Operating Current | I _{OP} | - | 26 | - | mA | F _{OSC} = 49.152MHz, AD, DAC disable, no loading | |
| Standby Current | I _{STB} | - | - | 2.0 | μA | Disable 32KHz crystal | |
| | | | | 5.0 | | Enable 32KHz, Disable PLL (Fosc) | |
| Input High Level | V _{IH} | - | 0.7VDD _{IO} | - | V | | |
| Input Low Level | V _{IL} | - | 0.3VDD _{IO} | - | V | | |
| Output DAC current (AUD1, AUD2) | I _{AUD} | - | -2.0 | - | mA | 2.0mA mode | For one channel DAC |
| | | | -3.0 | | | 3.0mA mode | |
| Output High Current | I _{OH} | - | -2.9 | - | mA | V _{OH} = 2.6V | |
| Output Low Current | I _{OL} | - | 6.7 | - | mA | V _{OL} = 0.7V | |
| Input Pull-Low Resistor (PA15 :0, PB15 :0) | R _{PL} | - | 175 | - | KΩ | VDD _{IO} = 3.3V V _{IN} = VDD | |
| Input Pull-High Resistor (PA15 :0, PB15 :0) | R _{PH} | - | 242 | - | KΩ | VDD _{IO} = 3.3V V _{IN} = VSS | |

7.5. ADC Characteristics (VDD = 3.3V, T_A = 25°C)

| Characteristics | Symbol | Unit | | | Unit |
|---|-------------------|-----------|------|-----------------------|--------------|
| | | Min. | Typ. | Max. | |
| ADC Power Dissipation for LINE_IN | I _{ADC} | - | 1.0 | - | mA |
| ADC Power Dissipation For MIC_IN | | - | 1.9 | - | mA |
| ADC LINE_IN Input Voltage Range from IOA[6:0] | VINL (Note 1) | VSS - 0.3 | - | VDD + 0.3 | V |
| ADC Microphone Input Voltage Range | VINM | VSS - 0.3 | - | VDD + 0.3 | V |
| External ADC Top Voltage | VEXTREF (Note 2) | 2.0 | - | VDD + 0.3 | V |
| Resolution of ADC | RESO | - | - | 10 | bits |
| Signal-to-Noise Plus Distortion of ADC from Line In | SINAD (Note 4) | - | 56 | - | dB |
| Effective Number of Bit | ENOB (Note 5) | - | 9.0 | - | bits |
| Integral Non-Linearity of ADC | INL | - | ±4.0 | - | LSB (Note 3) |
| Differential Non-Linearity of ADC | DNL (Note 6) | - | ±0.5 | - | LSB |
| AD Conversion Rate | F _{CONV} | - | - | F _{cpu} /512 | Hz |
| Microphone Amplifier Gain (Note 7) | A _{MIC} | - | - | 42 | dB |

Note1: Internal protection diodes clamp the analog input to VDD and VSS. These diodes allow the analog input to swing from (VSS-0.3V) to (VDD+0.3V) without causing damages to the devices.

Note2: The ADC performance is limited by the system noise level and therefore, the SPCE061A only guarantees to the 8-bit accuracy when VEXTREF is 2.0V.

Note3: The LSB means Least Significant Bit. VINL = 2.0V, 1LSB = 2.0V/2¹⁰ = 1.953mV.

Note4: The SINAD testing condition at VINLp-p = 0.8*VDD, F_{CONV} = F_{cpu}/512 = 49MHz/512 = 95KHz, Fin = 1.0KHz Sine waves at VDD = 3.0V from the IOA [6:0] input.

Note5: ENOB = (SINAD-1.76)/6.02.

Note6: The ADC of SPCE061A guarantees no data missed during conversion.

Note7: The microphone amplifier maximum gain = 15 * (60K / (1.5K + REXT)) V/V. The REXT is external resistor between OPI and MICOUT. The gain is 132V/V (=42dB) when REXT is 5.1K.

7.6. V2VREF Regulator Characteristics (VDD = 3.3V, T_A = 25°C)

| Characteristics | Symbol | Limit | | | Unit | Test Condition |
|-------------------------|------------------|-------|------|------|------|---------------------------------------|
| | | Min. | Typ. | Max. | | |
| Output Voltage Accuracy | V2VREF | 1.8 | 2.0 | 2.2 | V | AVDD = 3.3V, I _{OUT} ≤ 5mA |
| Output Current | I _{OUT} | - | 5.0 | - | mA | AVDD = 3.3V, V2VREF = 2.0V |
| Input Voltage | AVDD | 3.0 | 3.3 | 3.6 | V | I _{OUT} ≤ 5mA, V2VREF = 2.0V |

Note1: The V2VREF Regulator output current maximum ≤ 5mA, It is not matching to make a large current driver application. Our suggestion can be used as external ADC Line_IN reference voltage.

7.7. DAC Characteristics (VDD = 3.3V, T_A = 25°C)

| Characteristics | Symbol | Unit | | | Unit |
|------------------------------|----------------|------|------|------|------|
| | | Min. | Typ. | Max. | |
| DAC resolution | RESO | - | - | 10 | bit |
| Signal to Noise Ratio of DAC | SNR | - | 54 | - | dB |
| Sample Rate | F _s | - | - | 100K | Hz |

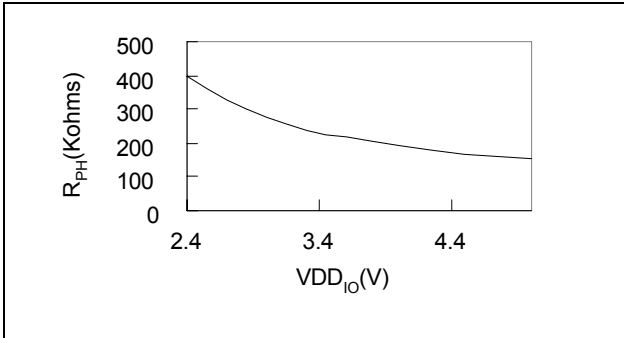
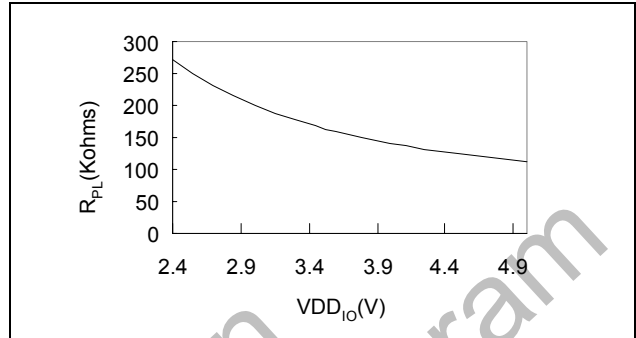
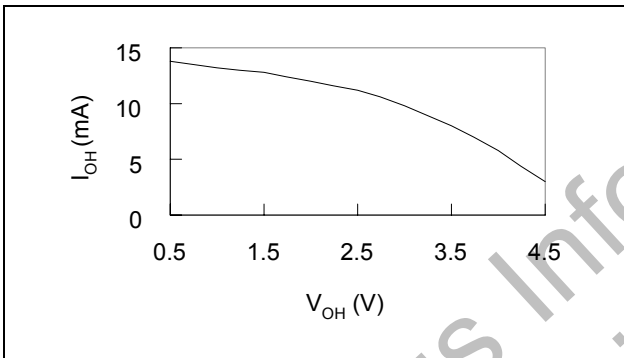
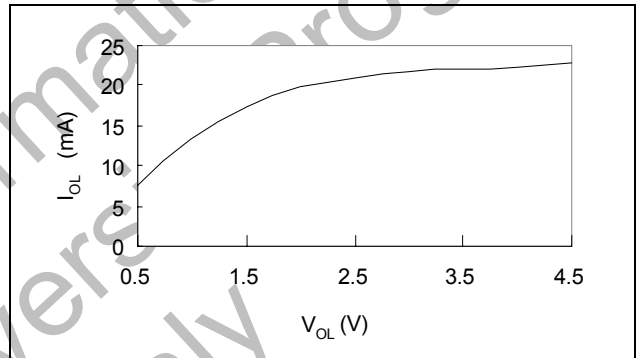
7.8. Pull High Resistor and V_{DDIO}

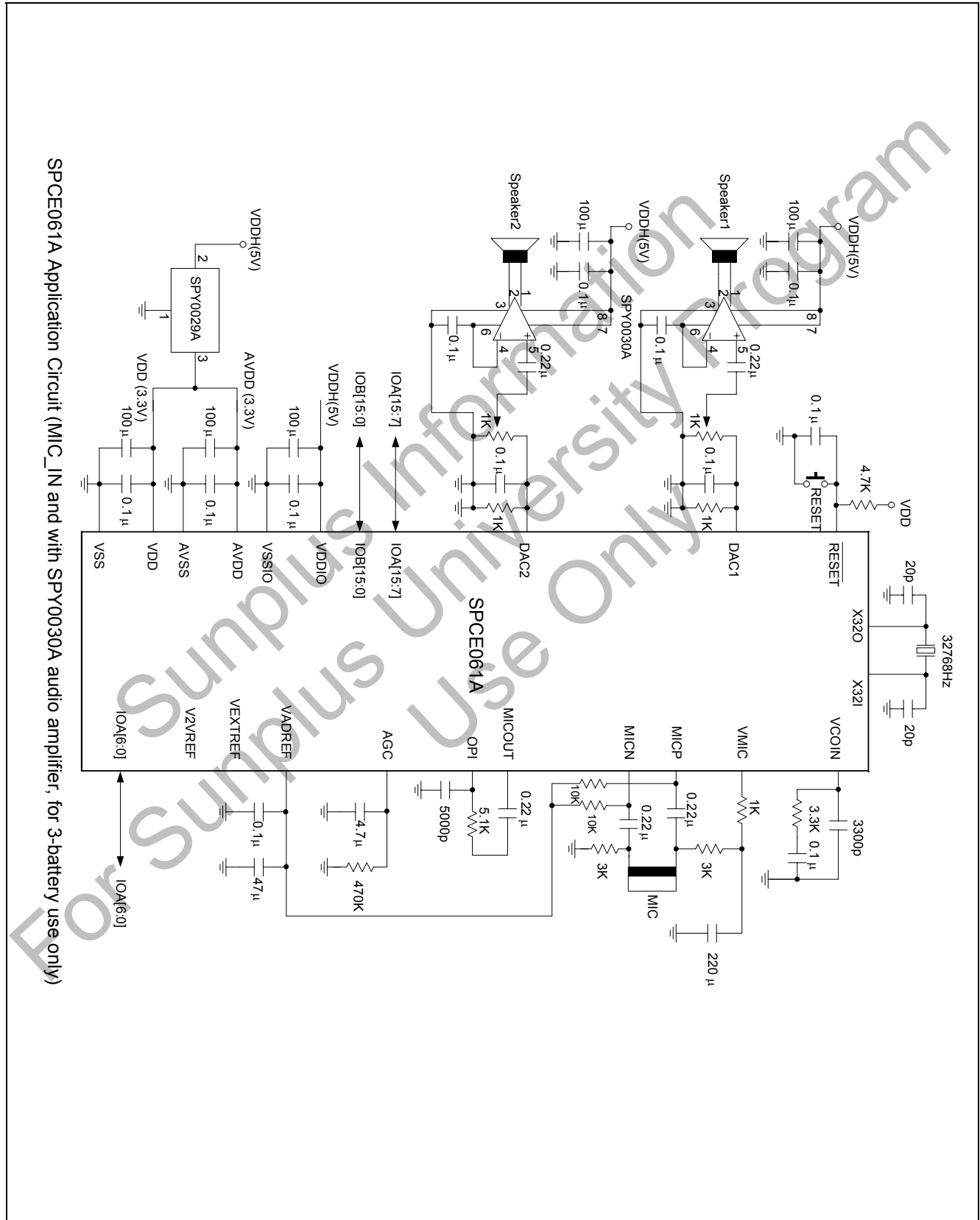
7.10. Pull Low Resistor and V_{DDIO}

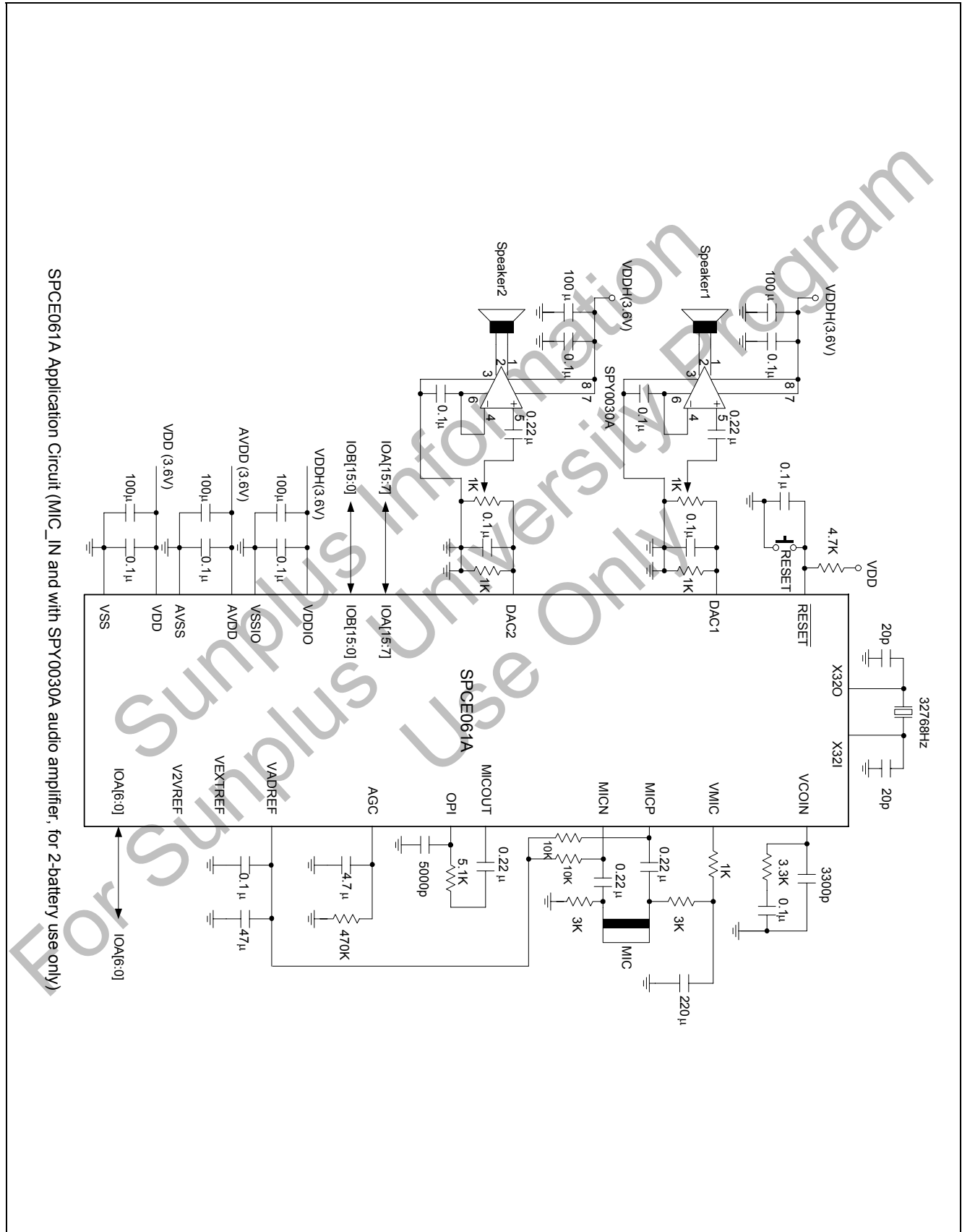
7.9. I/O Output High Current I_{OH} and V_{OH}

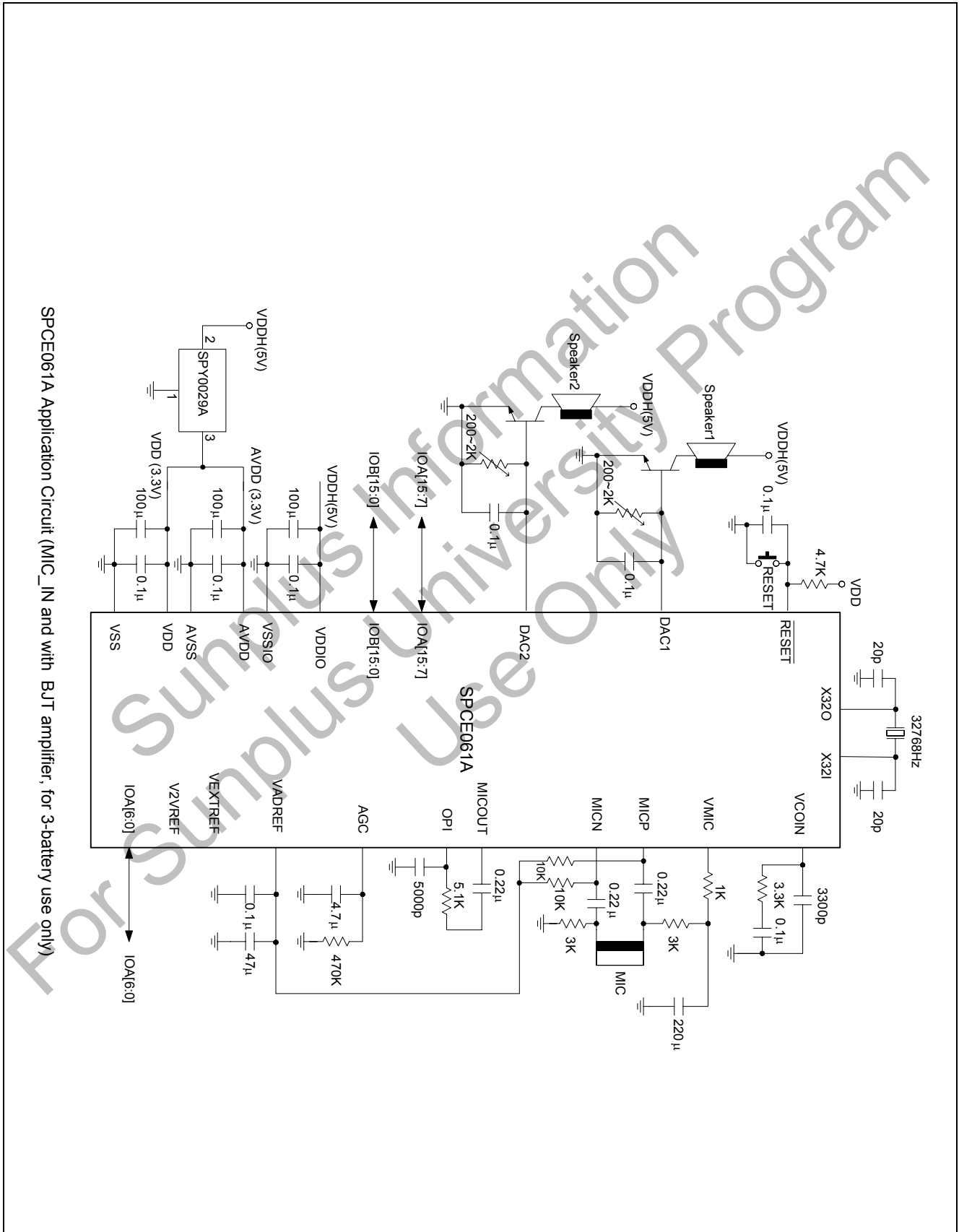
7.11. I/O Output Low Current I_{OL} and V_{OL}

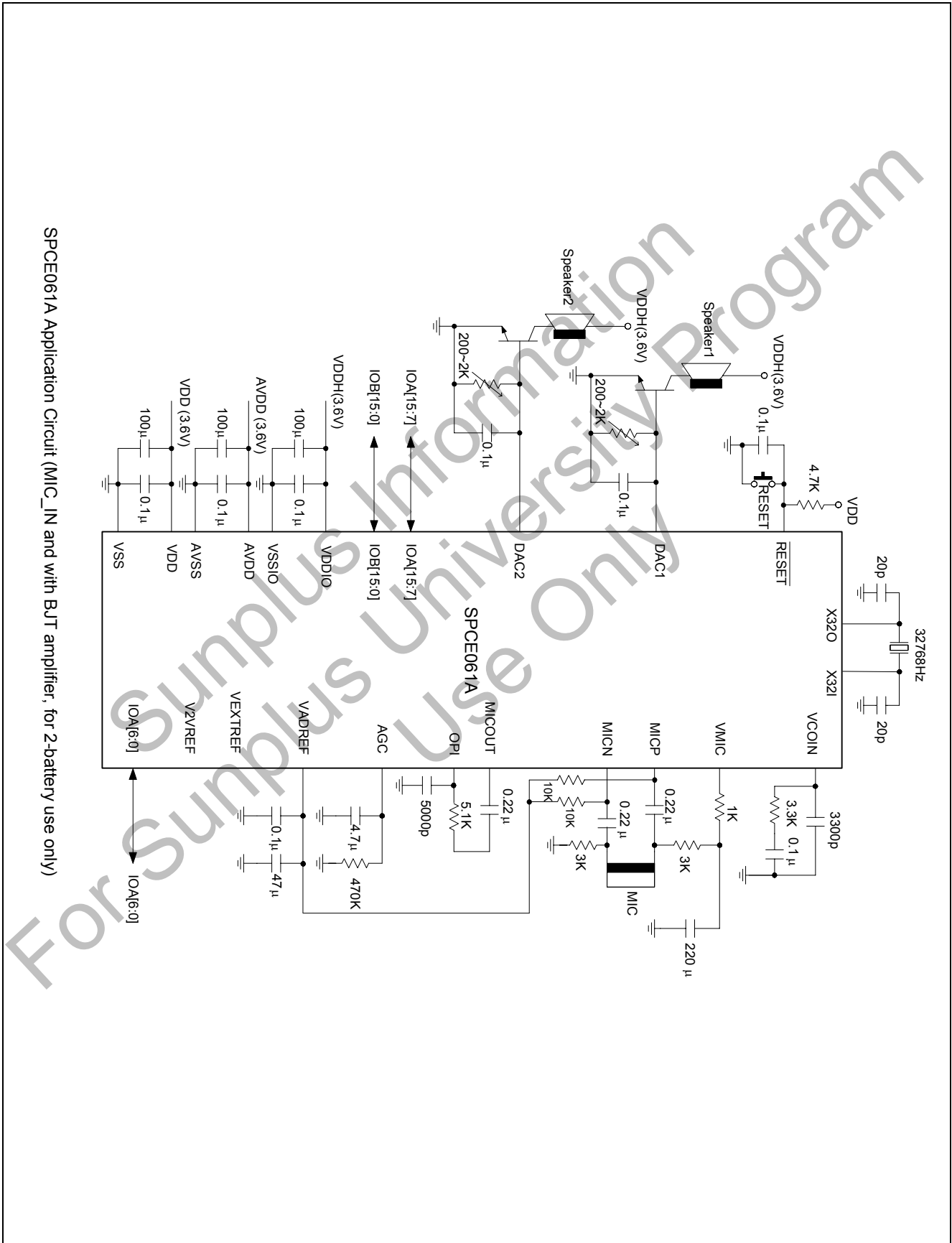
8. APPLICATION CIRCUITS
8.1. Application Circuit - (1)

8.2. Application Circuit - (2)

8.3. Application Circuit - (3)

8.4. Application Circuit - (4)

SPCE061A Application Circuit (MIC_IN and with BJT amplifier, for 2-battery use only)

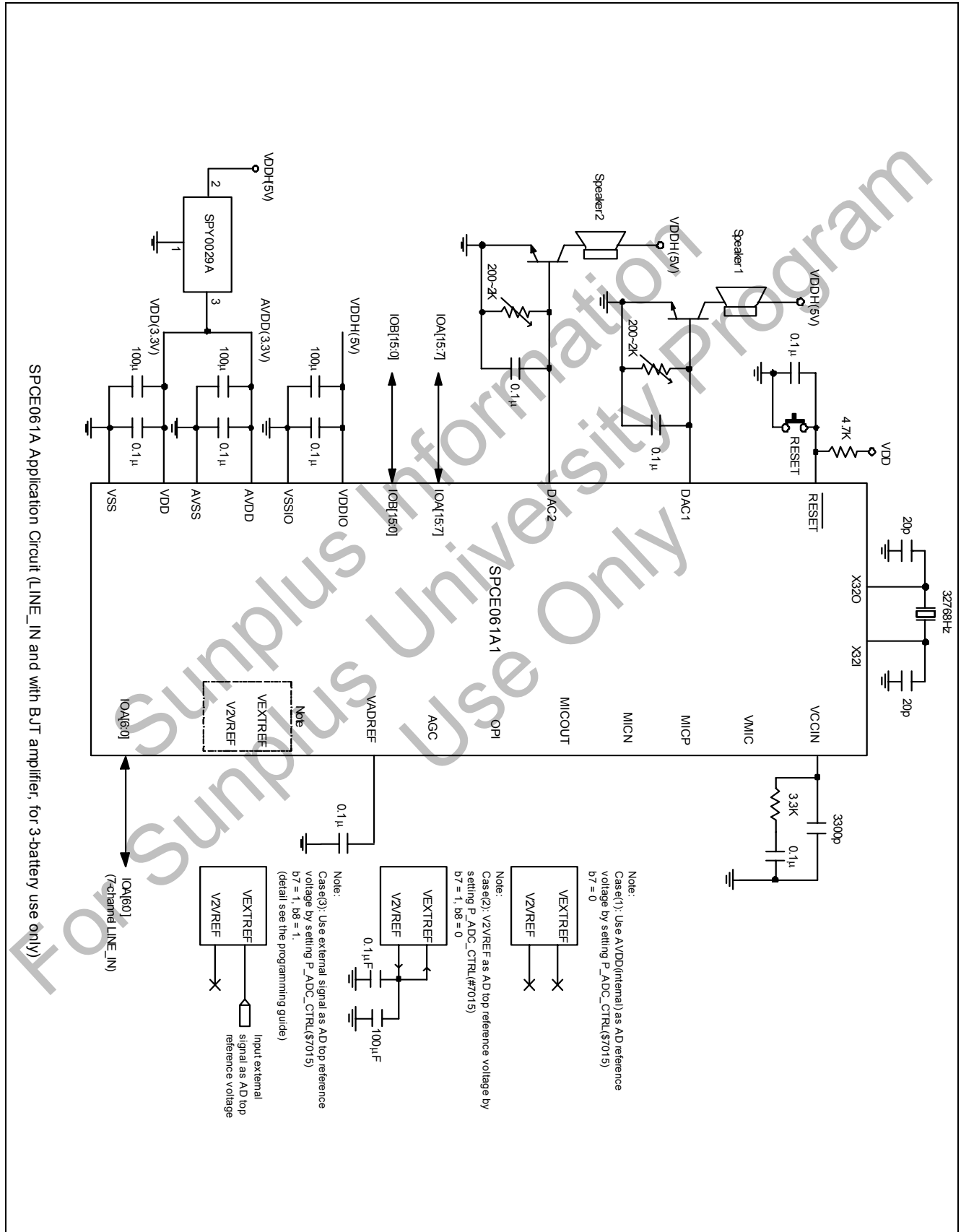
8.5. Application Circuit - (5)

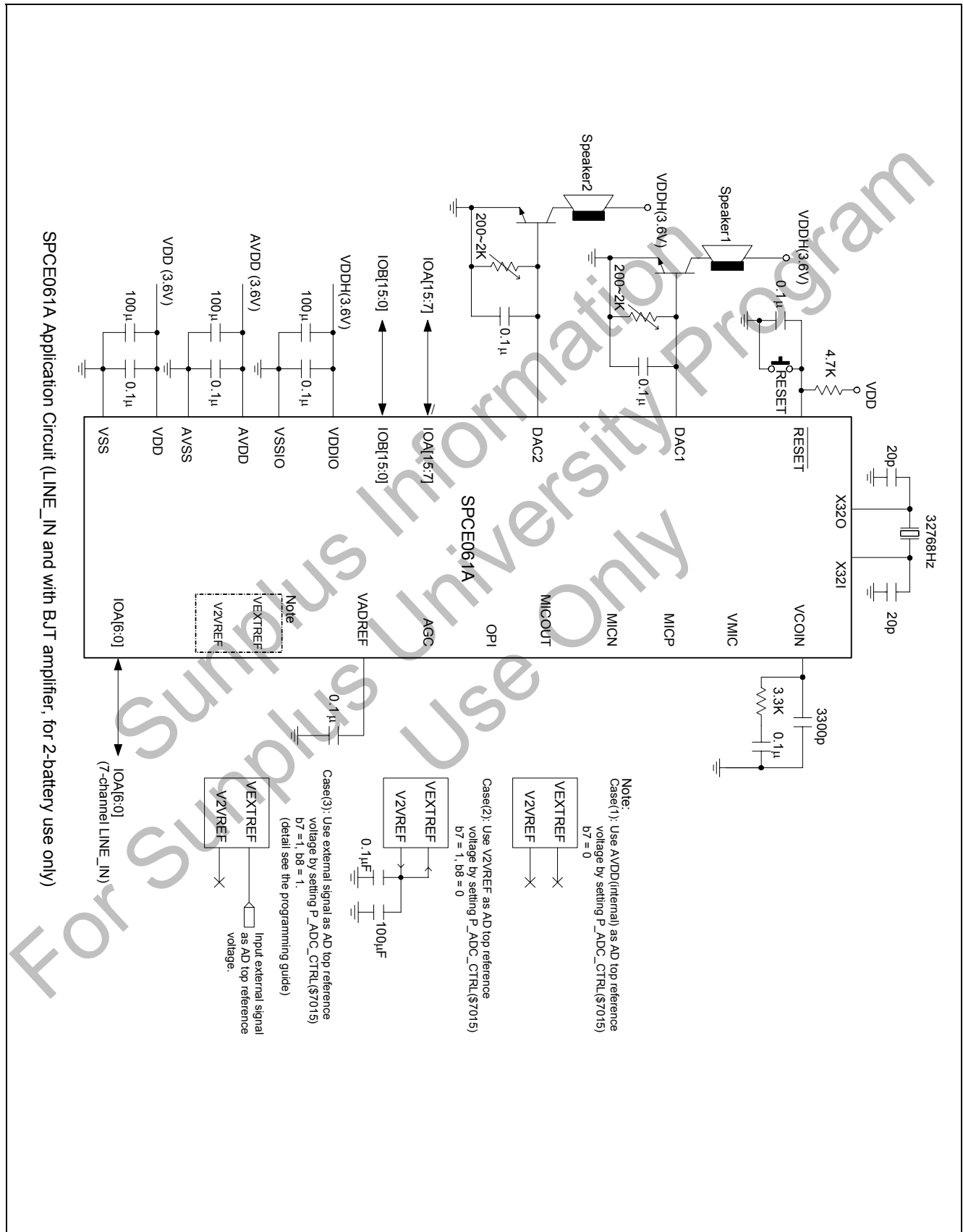
8.6. Application Circuit - (6)

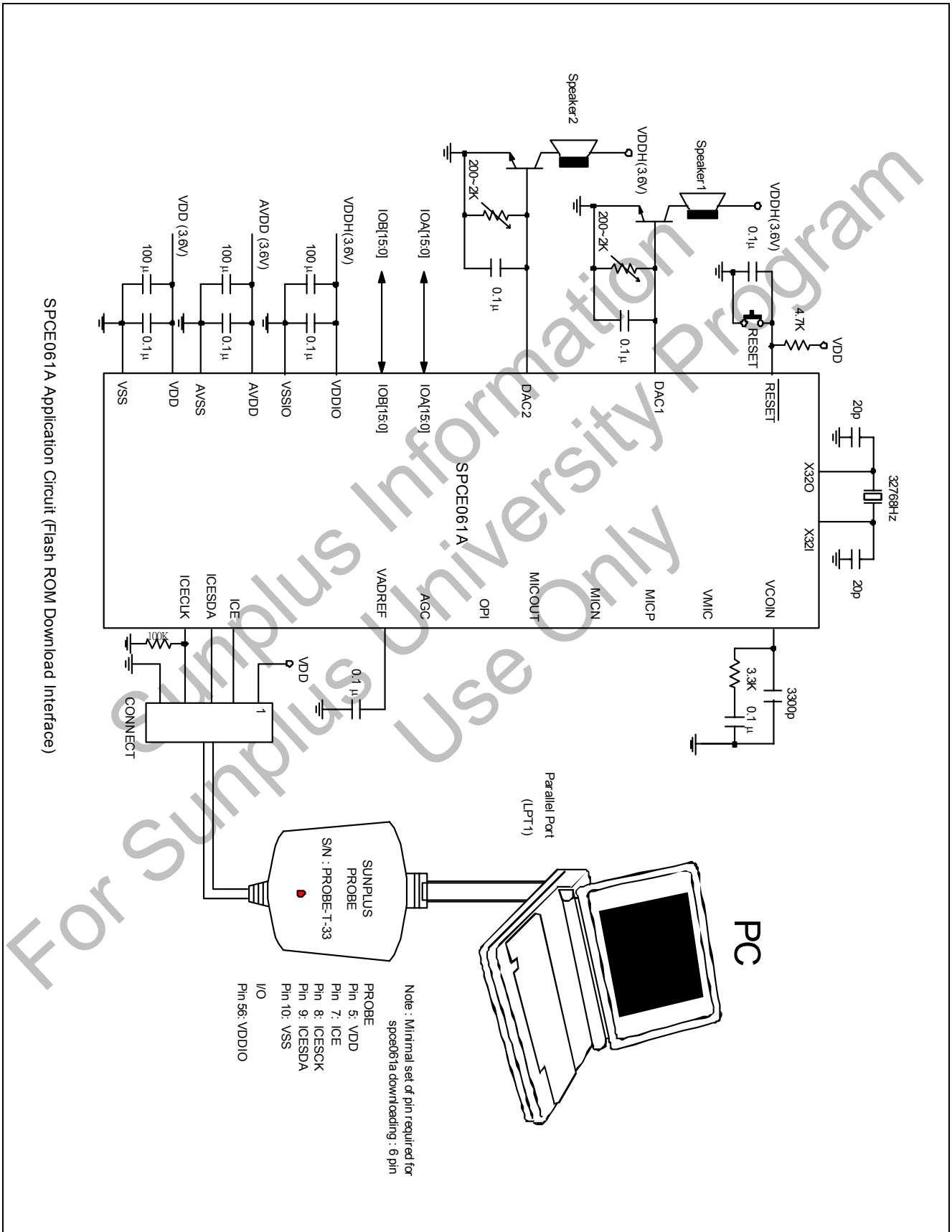
8.7. Application Circuit - (7)

9. PACKAGE/PAD LOCATIONS**9.1. PAD Assignment and Locations**

Please contact Sunplus sales representatives for more information.

Sunplus Information
For Sunplus University Program
Use Only

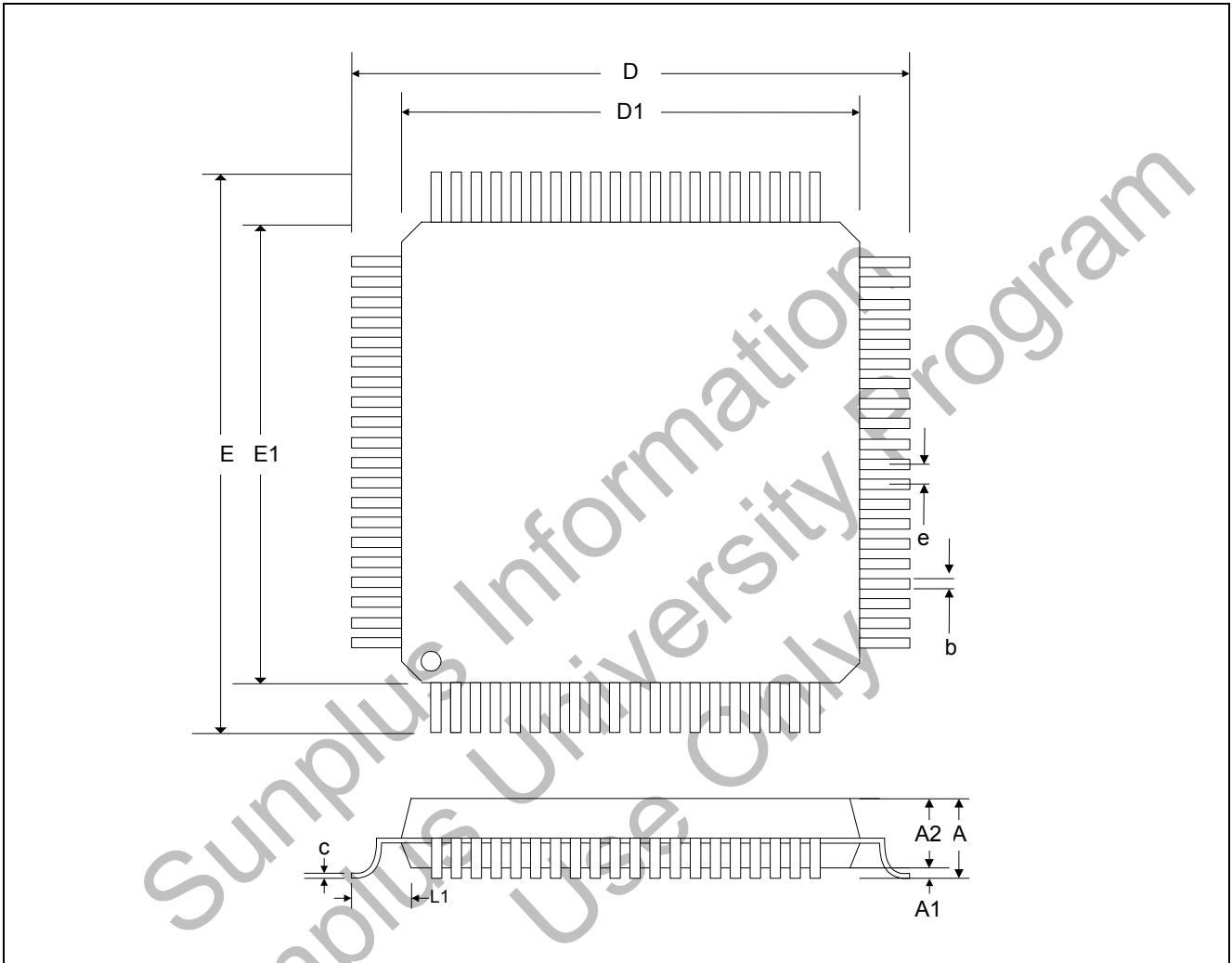
9.2. Package information
9.2.1. LQFP 80

| Symbol | Dimension in inch | | |
|--------|-------------------|-------|-------|
| | Min. | Typ. | Max. |
| A | - | - | 0.063 |
| A1 | 0.002 | - | 0.006 |
| A2 | 0.053 | 0.055 | 0.057 |
| b | 0.007 | 0.009 | 0.011 |
| c | 0.004 | - | 0.008 |
| D | 0.551 BSC. | | |
| D1 | 0.472 BSC. | | |
| E | 0.551 BSC. | | |
| E1 | 0.472 BSC. | | |
| e | 0.020 BSC. | | |
| L1 | 0.039 REF | | |

| PAD No. | PAD Name | PAD No. | PAD Name |
|---------|----------|---------|----------|
| 1 | X320 | 21 | MICP |
| 2 | X321 | 22 | VADREF |
| 3 | TEST | 23 | VEXTREF |
| 4 | N/C | 24 | AVDD |
| 5 | VDD | 25 | VMIC |
| 6 | N/C | 26 | N/C |
| 7 | ICE | 27 | VSS |
| 8 | ICECLK | 28 | IOA0 |
| 9 | ICESDA | 29 | IOA1 |
| 10 | VSS | 30 | IOA2 |
| 11 | PVIN | 31 | IOA3 |
| 12 | DAC1 | 32 | IOA4 |
| 13 | DAC2 | 33 | IOA5 |
| 14 | V2VREF | 34 | IOA6 |
| 15 | AVSS | 35 | IOA7 |
| 16 | AGC | 36 | VSSIO |
| 17 | OPI | 37 | VSSIO |
| 18 | MICOUT | 38 | VDDIO |
| 19 | MICN | 39 | VDDIO |
| 20 | PFUSE | 40 | IOA8 |
| 41 | N/C | 61 | N/C |
| 42 | N/C | 62 | N/C |
| 43 | IOA9 | 63 | IN/C |
| 44 | IOA10 | 64 | VDDIO |
| 45 | IOA11 | 65 | IOB10 |
| 46 | IOA12 | 66 | IOB9 |
| 47 | IOA13 | 67 | IOB8 |
| 48 | IOA14 | 68 | IOB7 |
| 49 | IOA15 | 69 | IOB6 |
| 50 | N/C | 70 | IOB5 |
| 51 | N/C | 71 | IOB4 |
| 52 | VSSIO | 72 | IOB3 |
| 53 | N/C | 73 | IOB2 |
| 54 | SLEEP | 74 | IOB1 |
| 55 | IOB15 | 75 | IOB0 |
| 56 | IOB14 | 76 | RESET |
| 57 | IOB13 | 77 | N/C |
| 58 | IOB12 | 78 | VDD |
| 59 | IOB11 | 79 | VCOIN |
| 60 | NC | 80 | VSS |

| PAD No. | PAD Name | PAD No. | PAD Name |
|---------|----------|---------|----------|
| 1 | IOB4 | 22 | DAC2 |
| 2 | IOB3 | 23 | V2VREF |
| 3 | IOB2 | 24 | AVSS |
| 4 | IOB1 | 25 | AGC |
| 5 | IOB0 | 26 | OPI |
| 6 | RESET | 27 | MICOUT |
| 7 | VDD | 28 | MICN |
| 8 | VCOIN | 29 | PFUSE |
| 9 | VSS | 30 | N/C |
| 10 | N/C | 31 | N/C |
| 11 | N/C | 32 | N/C |
| 12 | X32O | 33 | MICP |
| 13 | X32I | 34 | VADREF |
| 14 | TEST | 35 | VEXTREF |
| 15 | VDD | 36 | AVDD |
| 16 | ICE | 37 | VMIC |
| 17 | ICECLK | 38 | VSS |
| 18 | ICESDA | 39 | N/C |
| 19 | VSS | 40 | N/C |
| 20 | PVIN | 41 | IOA0 |
| 21 | DAC1 | 42 | IOA1 |
| 43 | IOA2 | 64 | IOB15 |
| 44 | IOA3 | 65 | IOB14 |
| 45 | IOA4 | 66 | IOB13 |
| 46 | IOA5 | 67 | IOB12 |
| 47 | IOA6 | 68 | IOB11 |
| 48 | IOA7 | 69 | N/C |
| 49 | VSSIO | 70 | N/C |
| 50 | VSSIO | 71 | N/C |
| 51 | VDDIO | 72 | N/C |
| 52 | VDDIO | 73 | N/C |
| 53 | IOA8 | 74 | N/C |
| 54 | IOA9 | 75 | VDDIO |
| 55 | IOA10 | 76 | IOB10 |
| 56 | IOA11 | 77 | IOB9 |
| 57 | IOA12 | 78 | IOB8 |
| 58 | IOA13 | 79 | IOB7 |
| 59 | IOA14 | 80 | IOB6 |
| 60 | IOA15 | 81 | IOB5 |
| 61 | N/C | 82 | N/C |
| 62 | VSSIO | 83 | N/C |
| 63 | SLEEP | 84 | N/C |

10. DISCLAIMER

The information appearing in this publication is believed to be accurate.

Integrated circuits sold by Sunplus Technology are covered by the warranty and patent indemnification provisions stipulated in the terms of sale only. SUNPLUS makes no warranty, express, statutory implied or by description regarding the information in this publication or regarding the freedom of the described chip(s) from patent infringement. FURTHER, SUNPLUS MAKES NO WARRANTY OF MERCHANTABILITY OR FITNESS FOR ANY PURPOSE. SUNPLUS reserves the right to halt production or alter the specifications and prices at any time without notice. Accordingly, the reader is cautioned to verify that the data sheets and other information in this publication are current before placing orders. Products described herein are intended for use in normal commercial applications. Applications involving unusual environmental or reliability requirements, e.g. military equipment or medical life support equipment, are specifically not recommended without additional processing by SUNPLUS for such applications. Please note that application circuits illustrated in this document are for reference purposes only.

Sunplus Information Program
For Sunplus University Program
Use Only

11. REVISION HISTORY

| Date | Revision # | Description | Page |
|---------------|------------|--|---|
| SEP. 09, 2003 | 0.5 | Update package information | 25 |
| SEP. 09, 2003 | 0.4 | 1 Correct Standby current condition 2 μ A @ VDD = 3.6V 2 Correct " <u>6.5.1 Low Voltage Detection (LVD)</u> " 3 Add "9.1 LQFP 80 and QPF84 package" | 1 8 24 - 28 |
| JAN. 30, 2003 | 0.3 | 1. Correct " <u>1. General Description</u> ". 2. Correct " <u>3. Features</u> ". 3. Correct " <u>5. Signal Descriptions</u> " PIN No. 4. 4. Correct " <u>6.5.1 Low Voltage Detection (LVD)</u> " 5. Correct " <u>6.7. I/O</u> " 6. Correct " <u>7.3. DC Characteristics</u> " Standby Current 7. Delete " <u>7.5 DC Characteristics (VDD = 2.7V, VDDIO = 2.7V (PORTA&B)</u> " 8. Delete " <u>7.6 DC Characteristics (VDD = 2.4V, VDDIO = 2.4V (PORTA&B)</u> " 9. Add " <u>9.1 PAD Assignment</u> " Note4 | 4 4 6 8 8 12 13 14 22 |
| NOV. 07, 2002 | 0.2 | 1. Add VDD = 3.6 / 3.3 / 2.7 / 2.4 V Standby Current "32Khz Enable, PLL Disable(Fosc)". 2. Add "6.2. DC Characteristics (VDD = 3.6V)". 3. Add "7.7. Application Circuit - (7)". 4. Add "7.8. V2VREF Regulator Characteristics". 5. Add "6.15 IDE Tools Function". 6. Correct "8.5. Application Circuit - (5)". 7. Correct "6.14. Bonding Option Summary". | 12,13,14 12 22 15 11 20 11 |
| AUG. 02, 2002 | 0.1 | Original | 24 |